

STL200/240



JOB NAME: _____
DATE: _____
TYPE: _____

DESCRIPTION

STEALTH Sensor with special 200° detection pattern to provide wide coverage side to side. Excellent for building perimeter protection. Blinders allow customization of detection zone.

SPECIFICATIONS

Advanced Detection Logic:

Minimizes false triggers

Color Matched Lens:

Dark lens with bronze units, white lens with white units

Floodlights:

Precision die cast aluminum. 1/2" NPS threaded arm with serrated locking swivel fits all standard mounting boxes and covers

Horizontal Lock, No-tool Joints:

Keeps sensing pattern level for fast, error-free installation

LED Detection Indicator:

Shows when sensor is detecting in daytime and glows red at night for "on-guard" deterrence

Photoelectric Control:

Deactivates lights during daylight. Fully adjustable for 24 hour operation or custom applications

Power Consumption:

1 watt

RF Immunity:

Circuits fully shielded for maximum radio frequency immunity

Surge Protection:

Withstands up to 6000 volts

Time Adjustment:

5 seconds to 12 minutes

Temperature Compensation:

Sensitivity adjusts automatically for consistent detection in hot and cold ambient temperatures

UL Listing:

Suitable for wet locations

Wall Switch Manual Override:

Two flip logic prevents activation by momentary power outages. Override resets to auto at dawn. No extra wiring needed

Wide Sensitivity Control:

Adjustable from 100% to 30%

Detection:

200° view

Lens Mask:

Customized press apply lens mask included to reduce coverage easily

Patents:

RAB sensor and fixture designs are protected under U.S. and International Intellectual Property laws

Switching Capacity:

1000 watts incandescent @ 120 volts, 8 amps

Voltage:

240 Volts, 50 Hertz

Color:

Bronze

Weight:

1.21

DIMENSIONS

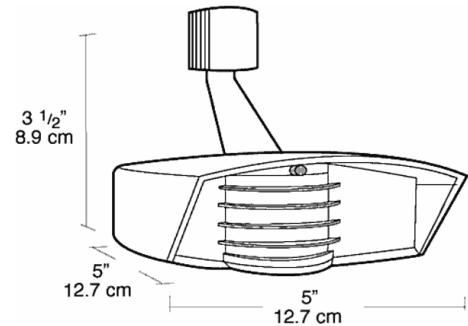

DETECTION PATTERN

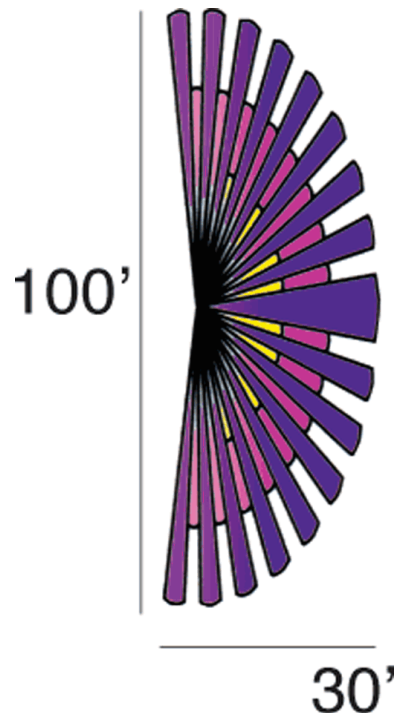

Note: Specifications may change without notice