

INSTALLATION INSTRUCTION

AETHER 2" SHALLOW RECESSED HOUSING

HR-2LED-H13A



SAFETY INSTRUCTION

IMPORTANT: NEVER attempt any work without shutting off the electricity.

- Read all instructions before installing.
- System is intended for installation by a qualified electrician in accordance with the National Electrical Code and local regulations.
- Place the wall switch in the "OFF" position.
- Go to the main fuse box or circuit breaker. Unscrew the fuse(s) or switch "OFF" the circuit breaker switch(es) that control the power to the space that you are working on.

CAUTION:

All parts must be used as indicated in these instructions. Do not substitute any parts, leave parts out, or use any parts that are worn out or broken. Failure to follow these instructions could invalidate the UL/cUL listing of this fixture.

AVERTISSEMENT:

IMPORTANT : COUPEZ L'ÉLECTRICITÉ AVANT TOUTE MANIPULATION.

- Lisez toutes les instructions avant d'installer.
- Système est destiné à être installé par un électricien qualifié en conformité avec le code national de l'électricité et les règlements locaux.
- Placez l'interrupteur mural en position d'arrêt (« OFF »).
- Accédez au panneau central de disjoncteurs ou de fusibles de votre demeure et placez l'interrupteur principal en position d'arrêt (« OFF »).

MISE EN GARDE:

Toutes les pièces doivent être utilisées tel qu'il est indiqué dans ces instructions. Ne remplacez pas les pièces, n'en laissez pas de côté et ne les utilisez pas si elles sont usées ou brisées. Le non-respect de ces instructions peut annuler l'homologation UL/cUL du luminaire.

OVERVIEW:

This housing is new construction IC Rated and Airtight. Housing requires a trim for finished look. Refer to specification sheets for compatible trim options.

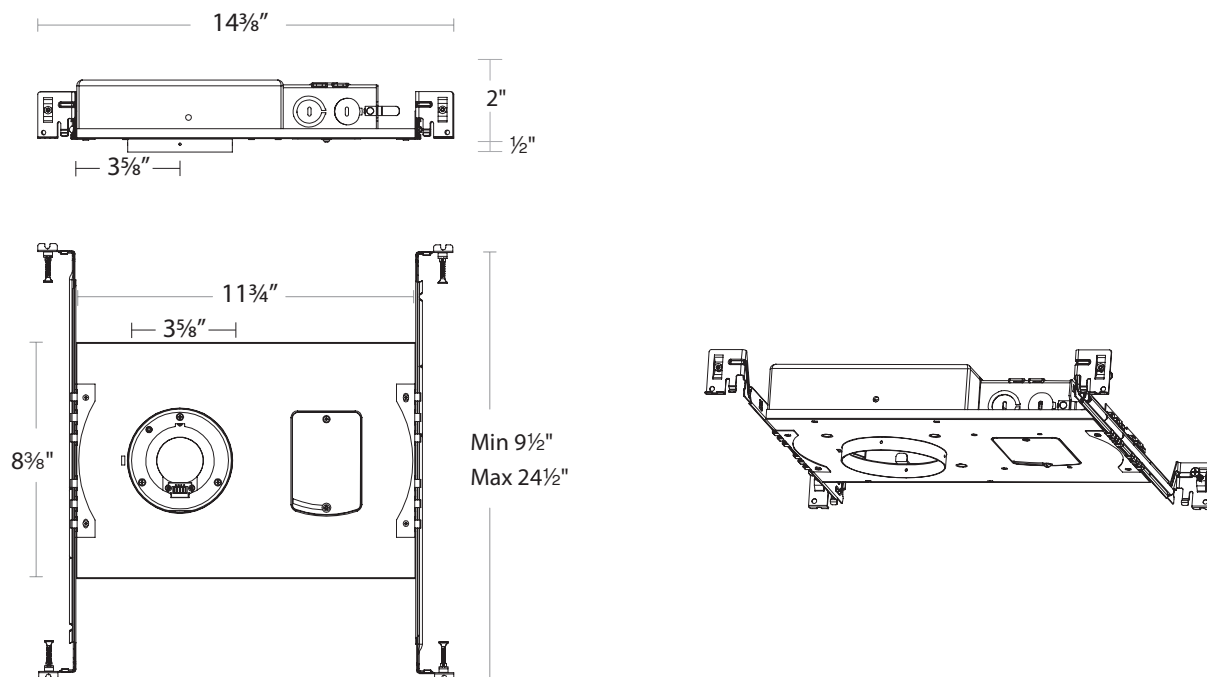

wacighting.com

Phone (800) 526.2588

Fax (800) 526.2585

Headquarters, East Manufacturing Facility

44 Harbor Park Drive

Port Washington, NY 11050

South East Manufacturing Facility

1600 Distribution Ct

Lithia Springs, GA 30122

Central Manufacturing Facility

1700 South J Elmer Freeway, Ste 100

Cedar Hill, TX 75104

West Manufacturing Facility

1750 S Archibald Ave

Ontario, CA 91761

INSTALLATION INSTRUCTION

AETHER 2" SHALLOW RECESSED HOUSING

HR-2LED-H13A



HOUSING INSTALLATION:

1. Install housing using two hanger bars provided. Align the bottom of the hanger bar with the bottom of the joist. Secure the "screw-nail" on each end by screwdriver or by hammer (See **FIG.1**, detail **A**).

Slide fixture along hanger bar into the desired location, use locking screws to secure (See **FIG.1**, detail **B**).

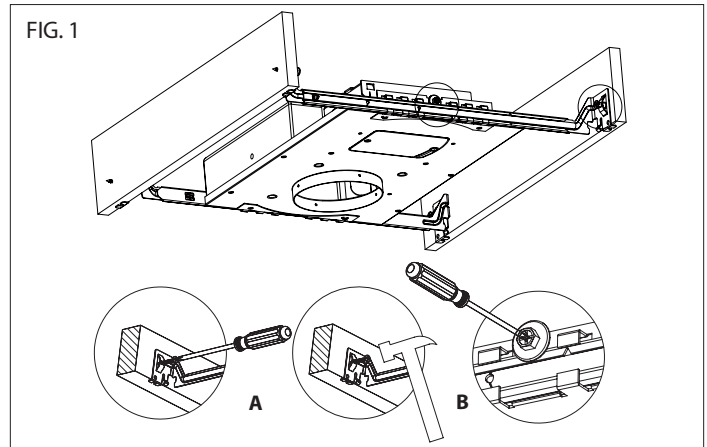

For grid installation, hanger bars are notched on the ends to fit over "T" bars in suspended ceilings. Support with tie wires (by others) to upper ceiling structure (See **FIG. 2**).

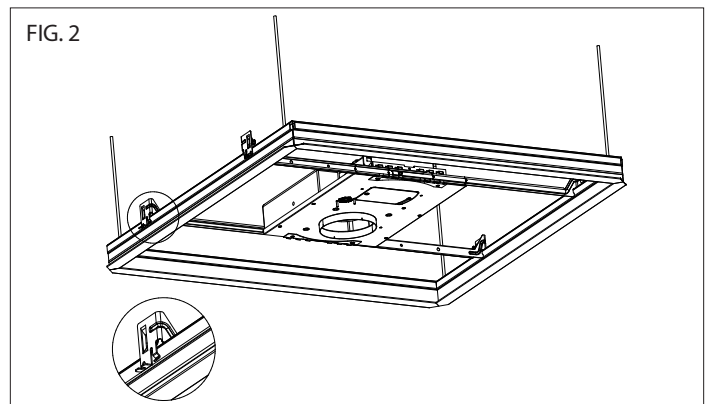

2. To shorten hanger bars to fit in a 12" joist, snap off one section of the hanger bars (See **FIG.3**).

WIRING OPTION A

- 1 Remove the latched junction box cover and connect fixture wires to building wires. Insert each supply wire into appropriate junction box connector. Connect black fixture wire to hot, white fixture wire to neutral, green fixture wire to ground, gray or pink fixture wire to Dim (-), and purple fixture wire to Dim (+) (See **FIG. 4**).

For ELV dimming, wire black (line hot) and white (line neutral) in accordance to dimmer specifications.

For 0-10V dimming, wire purple (dim+), gray or pink (dim-), black (line hot), and white (line neutral) in accordance to dimmer specifications.

When not using a dimmer, connect black fixture wire to hot, white fixture wire to neutral and green fixture wire to ground. Leave all other wires capped individually. Place all wiring and connectors back in junction box and replace the junction box cover.

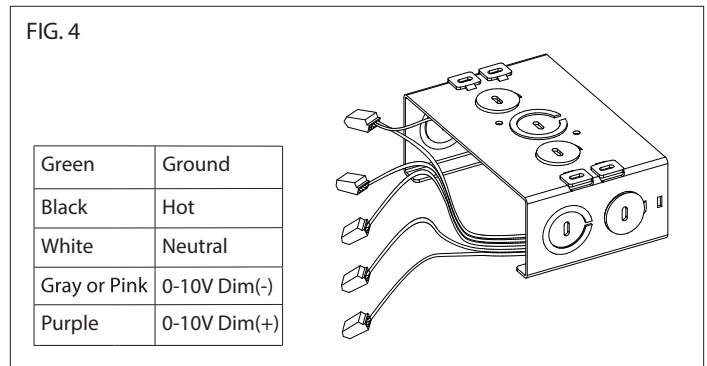
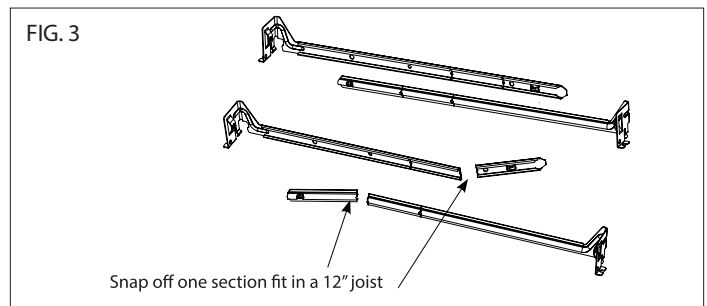

INSTALLATION INSTRUCTION

AETHER 2" SHALLOW RECESSED HOUSING

HR-2LED-H13A



WIRING OPTION B

1. Unscrew the housing cover from the base (**FIG.5**).

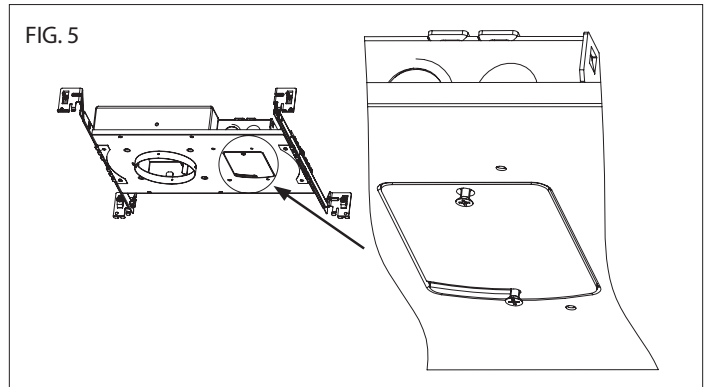

2. Swivel the housing cover to open (**FIG.6**).

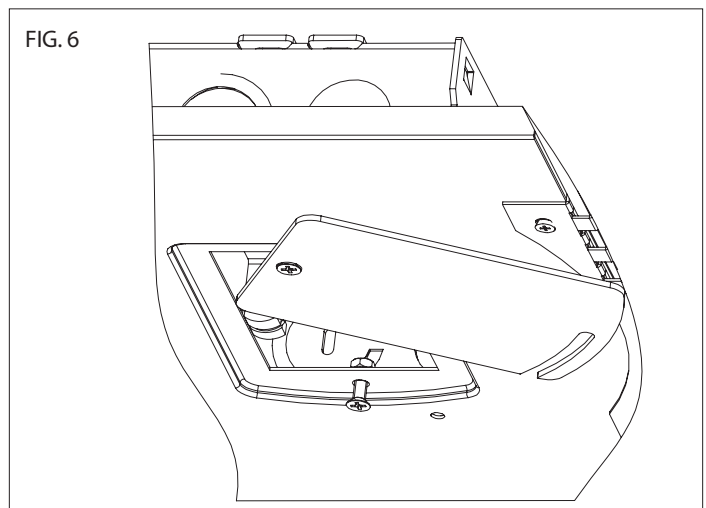

3. For ELV dimming, wire black (line hot) and white (line neutral) in accordance to dimmer specifications.

For 0-10V dimming, wire purple (dim+), gray or pink (dim-), black (line hot), and white (line neutral) in accordance to dimmer specifications (**FIG. 7**).

When not using a dimmer, connect black fixture wire to hot, white fixture wire to neutral and green fixture wire to ground. Leave all other wires capped individually.

4. Place all wiring and connectors back in junction box. Swivle the housing cover to the closed position and retighten the screw.

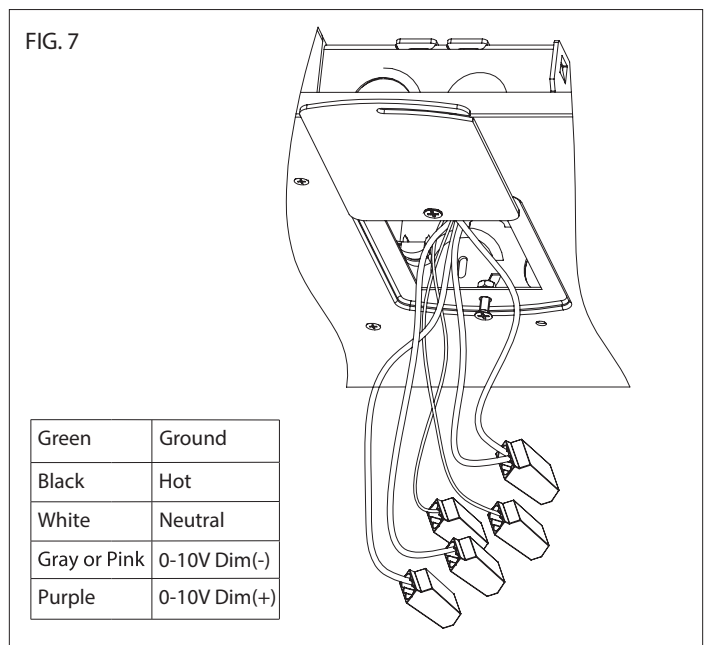

wacighting.com

Phone (800) 526.2588

Fax (800) 526.2585

Headquarters, East Manufacturing Facility

44 Harbor Park Drive

Port Washington, NY 11050

South East Manufacturing Facility

1600 Distribution Ct

Lithia Springs, GA 30122

Central Manufacturing Facility

1700 South J Elmer Freeway, Ste 100

Cedar Hill, TX 75104

West Manufacturing Facility

1750 S Archibald Ave

Ontario, CA 91761

INSTALLATION INSTRUCTION

AETHER 2" SHALLOW RECESSED HOUSING

HR-2LED-H13A



CEILING CUTOUT

Refer to the table below for hole cutout sizing.

Installation Type	Cutout Dimension
Trim	3 3/4" Dia.
Trimless	4 1/8" Dia.

TRIMLESS FRAME INSTALLATION

For trimmed version, skip to the appropriate section: Downlight (page 4), Adjustable (page 5), or Wall Wash (page 6).

1. Raise the trimless frame to the housing, ensuring the tab is aligned with the slot in housing (See **FIG. 8**).
2. Ensure the foam plaster shield is installed (See **FIG. 8**).
3. Secure the trimless frame to the housing, flush up against the ceiling using the screws supplied (See **FIG. 9**).

NOTE: If necessary, the square trimless frame has $\pm 5^\circ$ of rotation to fine-tune alignment. Remove the tab (shown in **FIG. 8**) and rotate as needed.

4. Apply plaster or spackle over trimless frame and sand surface when dry for a finished look (**FIG. 10**). Remove the plaster shield when finishing is complete (**FIG. 11**).

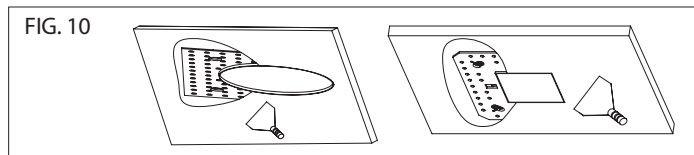

DOWNLIGHT INSTALLATION

1. Once housing is installed, place the downlight light engine into the housing by aligning the base with the slots in the housing receptacle. The light engine will magnetically click into place (**FIG. 12** and **FIG. 13**). The included handle is to aid with installation and removal of the light engine.

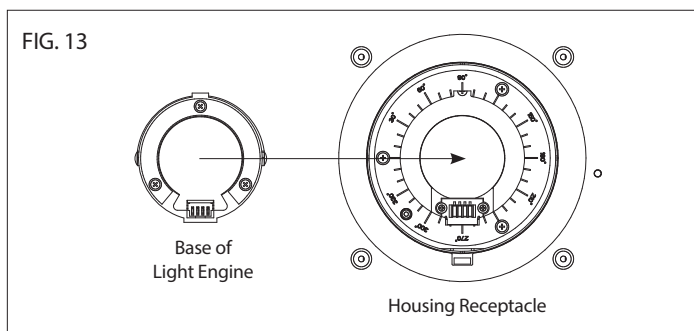

2. For trimmed version, raise the trim to housing, depress trim spring clips and push the trim assembly up until the trim ring is flush to the ceiling (**FIG. 14A**).

For trimless frame installation, push the trim element up into the housing aperture until it snaps into place (**FIG. 14B**).

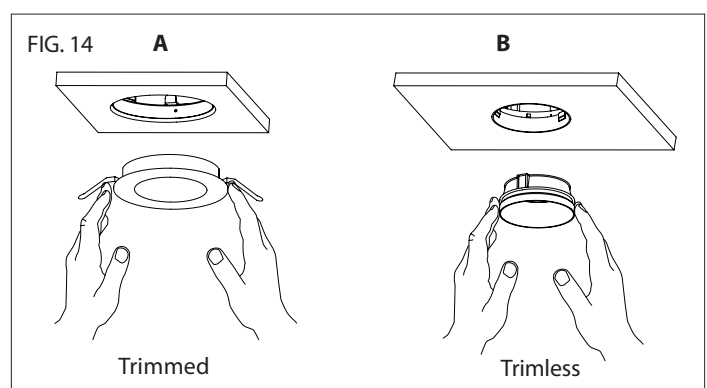
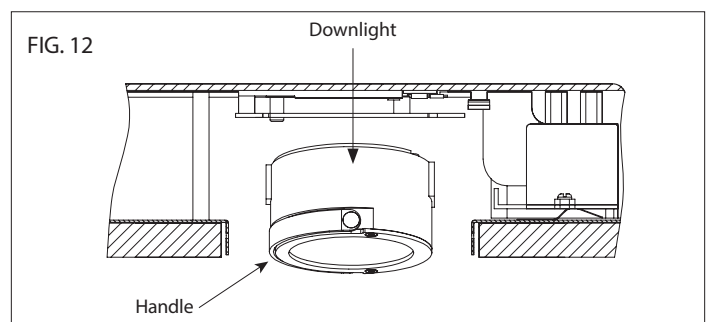
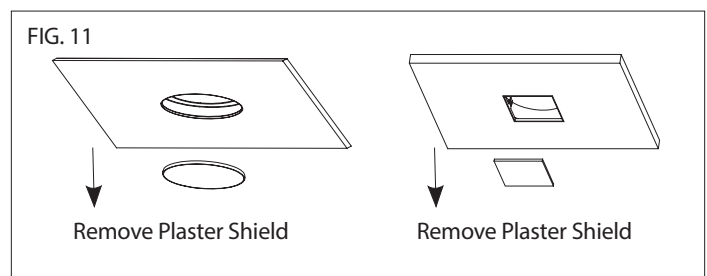
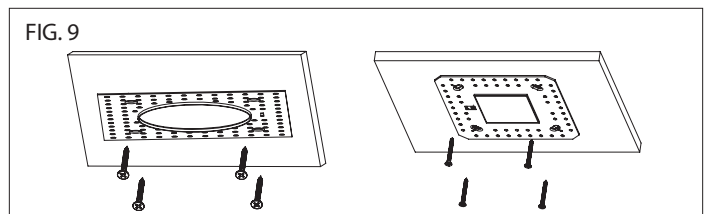
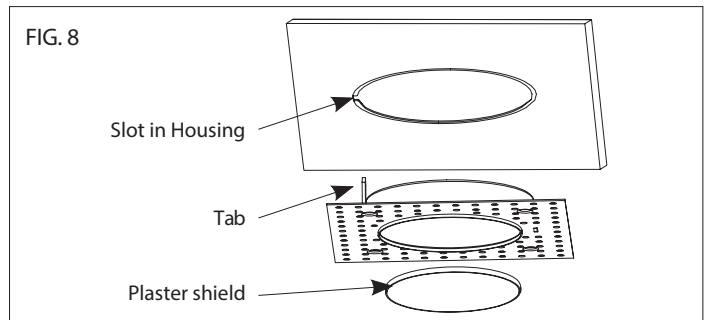

wacighting.com
Phone (800) 526.2588
Fax (800) 526.2585

Headquarters, East Manufacturing Facility
44 Harbor Park Drive
Port Washington, NY 11050

South East Manufacturing Facility
1600 Distribution Ct
Lithia Springs, GA 30122

Central Manufacturing Facility
1700 South J Elmer Freeway, Ste 100
Cedar Hill, TX 75104

West Manufacturing Facility
1750 S Archibald Ave
Ontario, CA 91761

INSTALLATION INSTRUCTION

AETHER 2" SHALLOW RECESSED HOUSING

HR-2LED-H13A



ADJUSTABLE DOWNLIGHT INSTALLATION

- Once housing is installed, place the adjustable downlight light engine into the housing by aligning the base with the slots in the housing receptacle. The light engine will magnetically click into place (**FIG. 15** and **FIG. 16**). The included handle is to aid with installation, adjustment and removal of the light engine.

FIG. 15

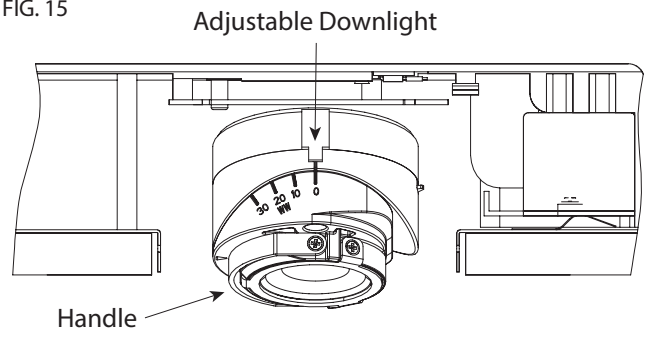
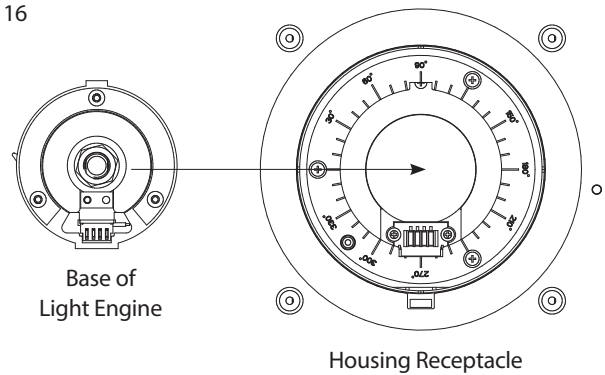

FIG. 16



- The adjustable downlight light engine has a max horizontal rotation of 365° and a max vertical tilt of 30° (**FIG. 17**).
Note: if using a trim with lens installed, max vertical tilt is 25°.

- Adjust the vertical tilt to desired angle.

FIG. 17

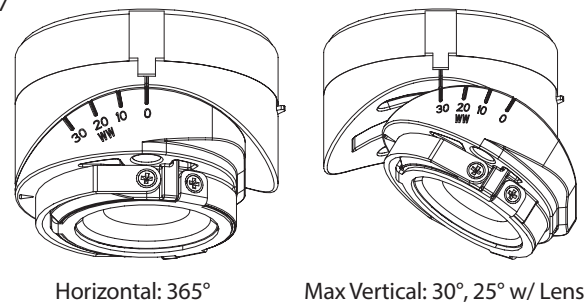

- For trimmed version, raise the trim to housing, depress trim spring clips and push the trim assembly up until the trim ring is flush to the ceiling (**FIG. 18A**).

For trimless frame installation, push the trim element up into the housing aperture until it snaps into place (**FIG. 18B**).

FIG. 18

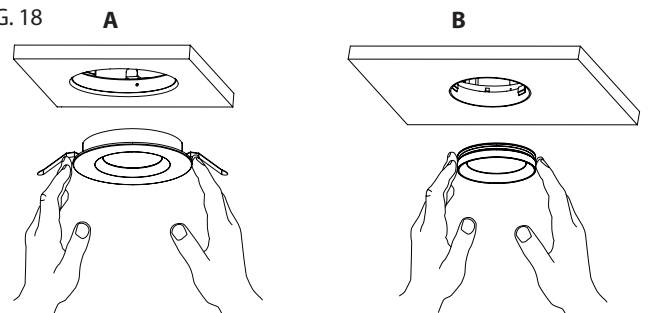

wacighting.com

Phone (800) 526.2588

Fax (800) 526.2585

Headquarters, East Manufacturing Facility

44 Harbor Park Drive

Port Washington, NY 11050

South East Manufacturing Facility

1600 Distribution Ct

Lithia Springs, GA 30122

Central Manufacturing Facility

1700 South J Elmer Freeway, Ste 100

Cedar Hill, TX 75104

West Manufacturing Facility

1750 S Archibald Ave

Ontario, CA 91761

INSTALLATION INSTRUCTION

AETHER 2" SHALLOW RECESSED HOUSING

HR-2LED-H13A



WALL WASH INSTALLATION

1. Once housing is installed, place the wall wash light engine into the housing by aligning the base with the slots in the housing receptacle. The light engine will magnetically click into place (**FIG. 19** and **FIG. 20**). The included handle is to aid with installation, adjustment and removal of the light engine.

2. Set the tilt angle to 20°. Be sure to adjust the horizontal aiming to the desired direction as the light engine will also dictate the direction of the trim.

3. For trimmed version, raise the trim to housing, depress trim spring clips and push the trim assembly up until the trim ring is flush to the ceiling (**FIG. 21A**).

For trimless frame installation, push the trim element up into the housing aperture until it snaps into place (**FIG. 21B**).

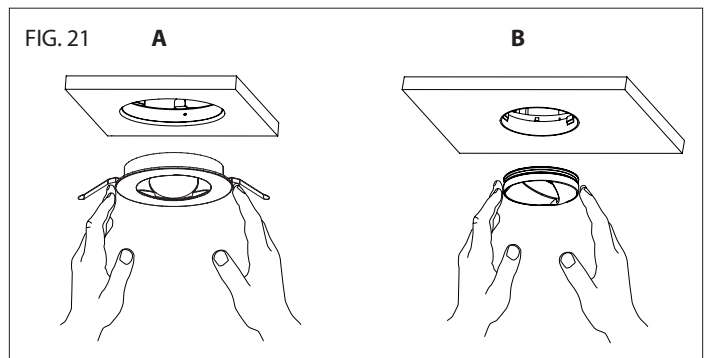
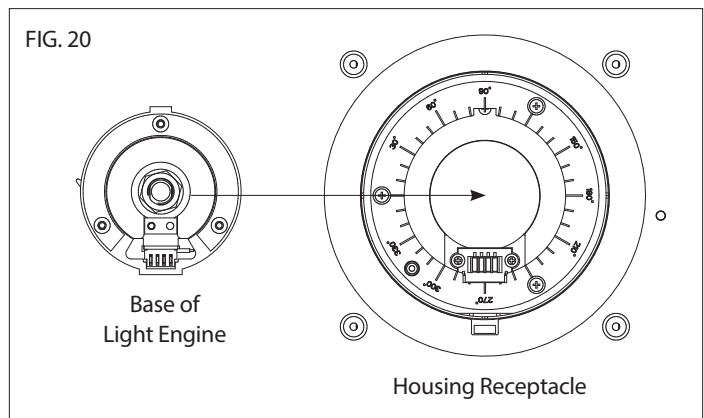
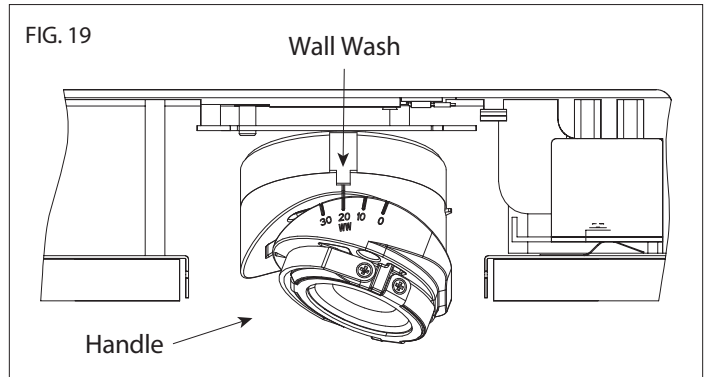

INSTALLATION INSTRUCTION

AETHER 2" SHALLOW RECESSED HOUSING

HR-2LED-H13A



REPLACING THE DRIVER

1. Remove Trim Frame from the housing (**FIG.22**). If using a trimless frame, insert screwdriver between trim top and lens bottom (lens will lift slightly) to remove trim from housing (**FIG.23**).

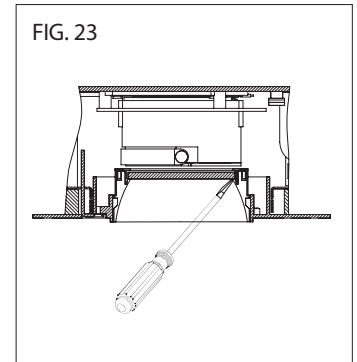
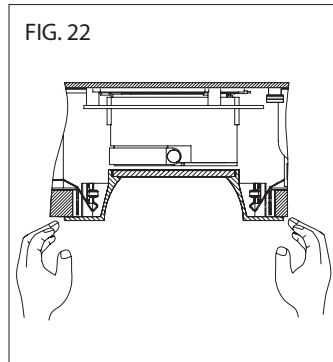

2. Flip the adjustment handle down and gently pull to remove the light engine from the housing (**FIG.24**).

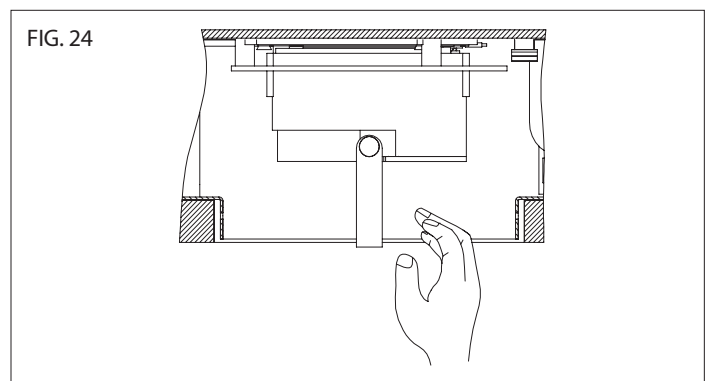

3. Locate the driver within the housing (visible from aperture). Slide the driver door to the side to free the driver (**FIG.25**).

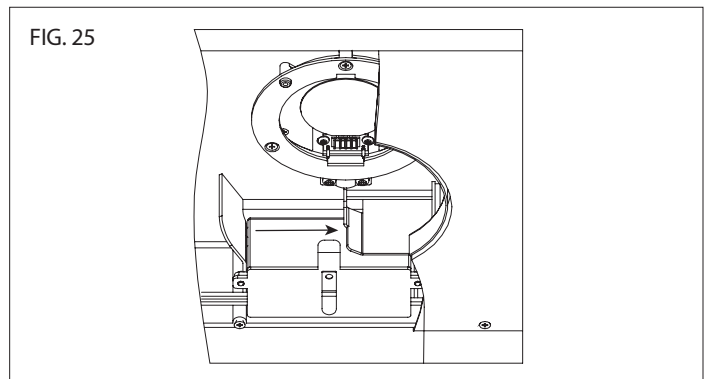

4. Disconnect the wires and replace with the new driver (**FIG.26**).

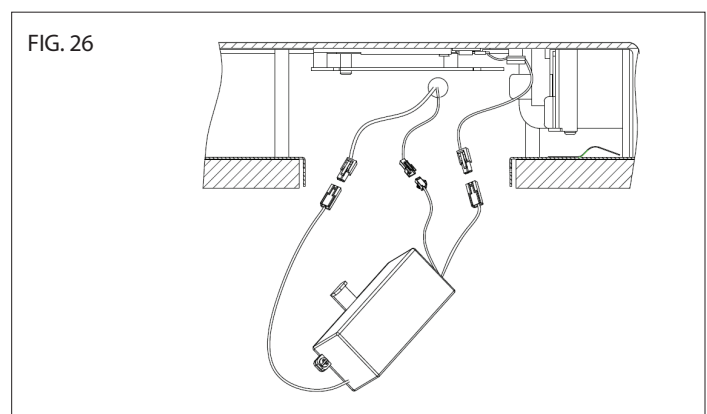

wacighting.com

Phone (800) 526.2588

Fax (800) 526.2585

Headquarters, East Manufacturing Facility

44 Harbor Park Drive

Port Washington, NY 11050

South East Manufacturing Facility

1600 Distribution Ct

Lithia Springs, GA 30122

Central Manufacturing Facility

1700 South J Elmer Freeway, Ste 100

Cedar Hill, TX 75104

West Manufacturing Facility

1750 S Archibald Ave

Ontario, CA 91761